



## FAMATEX STENTERS

body dimensions				fill						Gutmann article-nr.
inner ø (di/d2)	outer ø (da)	width (b)	pitch circle Ø (TK)	fill material	trim mm	rows	operating width (B) mm	style		
mm	mm	mm	mm					straight	conv.	
										

### Overfeed and Postpinning Brush Ø 201 mm (D)

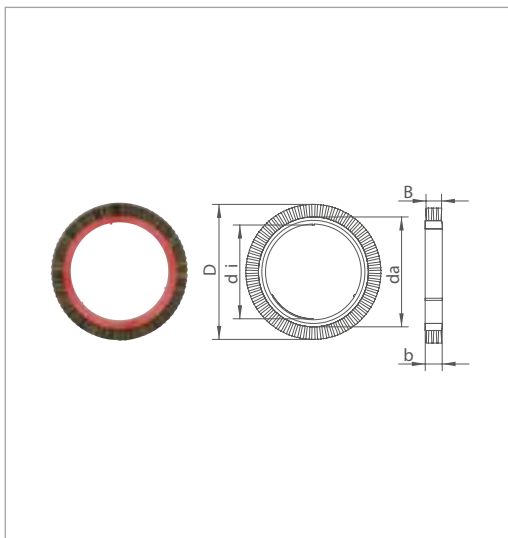

140	164.0	25.0		Calcutta bristle grey	18.5	4	17	•		8101-0201-04
140	164.0	25.0		horsehair black	18.5	4	19	•		8101-0201-24
140	164.0	25.0		horsehair black	18.5	6	22	•		8101-0201-26
140	164.0	25.0		Chungking bristle black	18.5	4	18	•		8101-0201-34
140	164.0	25.0		Chungking bristle black	18.5	6	22	•		8101-0201-36
140	164.0	25.0		PA 6.6 white 0.40 mm	18.5	6	22	•		8101-0201-46
140	164.0	25.0		Calcutta bristle grey	18.5	6	22	•		8101-0201-56
140	164.0	25.0		PA 6.6 white 0.70 mm	18.5	4	18	•		8101-0201-74
140	164.0	25.0		PA 6.6 white 0.70 mm	18.5	6	22	•		8101-0201-76
140	164.0	25.0		stainless steel wire 0.25 mm	18.5	6	21	•		8101-0201-86
140	164.0	25.0		goat hair white	18.5	6	25	•		8101-0201-Z6
140	164.0	25.0		PA 6.6 white 0.80 mm	18.5	4	13		•	8101-1201-N4

### Overfeed and Postpinning Brush Ø 201 mm (D). inclined in direction of rotation

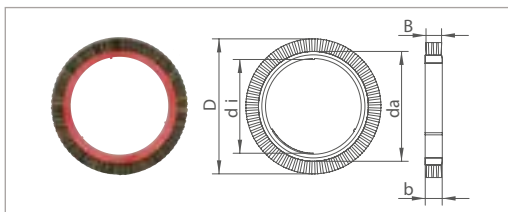

140	164.0	25.0		Chungking bristle black	18.5	6	21	•		8101-2201-36
140	164.0	25.0		Calcutta bristle grey	18.5	6	21	•		8101-2201-56

## FAMATEX STENTERS

body dimensions				fill						Gutmann article-nr.
inner $\varnothing$ (di/d2)	outer $\varnothing$ (da)	width (b)	pitch circle $\varnothing$ (TK)	fill material	trim	rows	operating width (B)	style		
mm	mm	mm	mm					mm	mm	
										

### Brush for cutting device $\varnothing$ 85 mm (D) (also check bushings for 8411-....-..)

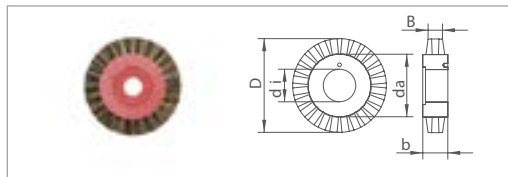

26	50.0	20.0		Calcutta bristle grey	17.5	4	18	•		<b>8411-0085-54</b>
----	------	------	--	-----------------------	------	---	----	---	--	---------------------

### Postpinning Brush $\varnothing$ 75 mm (D) (also check bushings for 8411-....-..)

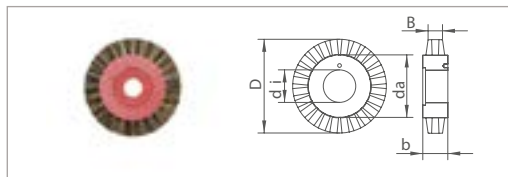

26	50.0	20.0		Calcutta bristle grey	12.5	3	10		•	<b>8411-1075-03</b>
26	50.0	20.0		Chungking bristle black	12.5	3	10		•	<b>8411-1075-13</b>

### Bushings for 8411-....-.. (50-8412 with key slot (for cutting device))

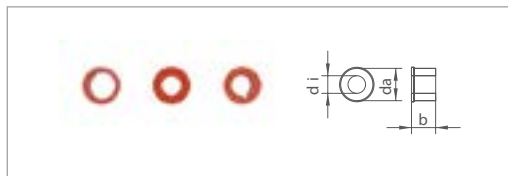

14	26	19.5								<b>50-8411</b>
15	26	19.5								<b>50-8412</b>

We offer the world's most extensive product portfolios of stenter brushes.  
If, contrary to expectations, none of them fits your requirements,  
please ask us to for an individual production of your stenter brush.