



ARTOS STENTERS

body dimensions			
inner \varnothing (di/d2)	outer \varnothing (da)	width (b)	pitch circle \varnothing (TK)
mm	mm	mm	mm

fill					
fill material	trim	rows	operating width (B)	style	
				straight	conv.
	mm		mm		

Gutmann article-nr.

Postpinning Brush \varnothing 180 mm (D)

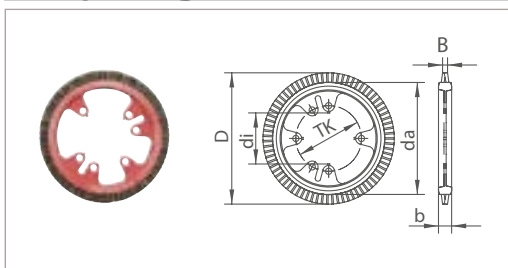

70	154.0	18.0	90.0	Calcutta bristle grey	13.0	2	8		•	8111-1180-02
70	154.0	18.0	90.0	Chungking bristle black	13.0	2	7		•	8111-1180-12
70	154.0	18.0	90.0	horsehair black	13.0	2	11		•	8111-1180-22
70	154.0	18.0	90.0	PA 6.6 white 0.40 mm	13.0	2	7		•	8111-1180-42
70	154.0	18.0	90.0	PA 6.6 white 0.70 mm	13.0	2	8		•	8111-1180-72
70	154.0	18.0	90.0	stainless steel wire 0.25 mm	13.0	2	11		•	8111-1180-82

Overfeed Brush \varnothing 200 mm (D)

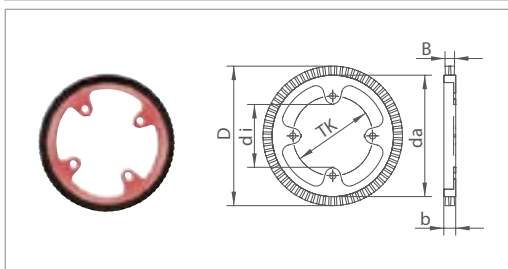

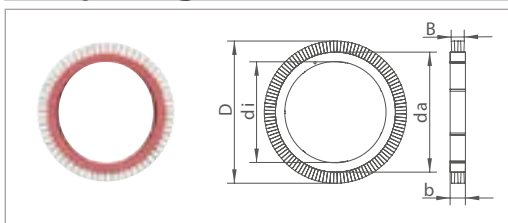

90	174.0	17.0	114.5	Calcutta bristle grey	13.0	3	14	•		8121-0200-03
90	174.0	17.0	114.5	Chungking bristle black	13.0	3	14	•		8121-0200-13
90	174.0	17.0	114.5	horsehair black	13.0	3	14	•		8121-0200-23
90	174.0	17.0	114.5	PA 6.6 white 0.40 mm	13.0	3	14	•		8121-0200-43

Postpinning Brush \varnothing 206 mm (D) (year 1988 till 1991)



145.1	173.0	22.0	P	PA 6.6 white 0.40	16.5	3	16		•	8331-1206-43
-------	-------	------	---	-------------------	------	---	----	--	---	--------------

ARTOS STENTERS

body dimensions				fill						Gutmann article-nr.
inner \emptyset (di/d2)	outer \emptyset (da)	width (b)	pitch circle \emptyset (TK)	fill material	trim mm	rows	operating width (B) mm	style		
mm	mm	mm	mm					straight	conv.	
										

Overfeed and Postpinning Brush \emptyset 206 mm (D)

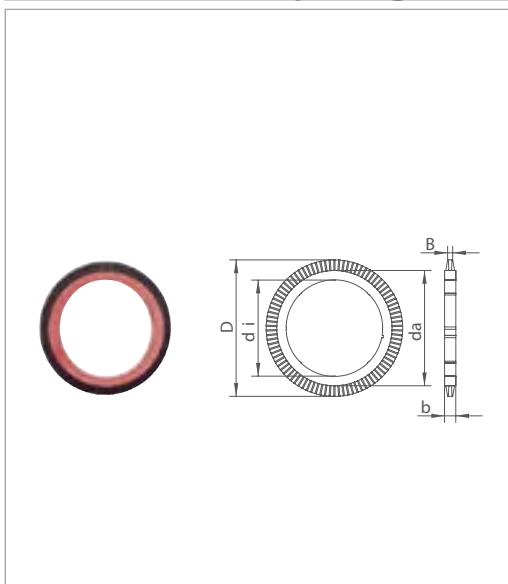

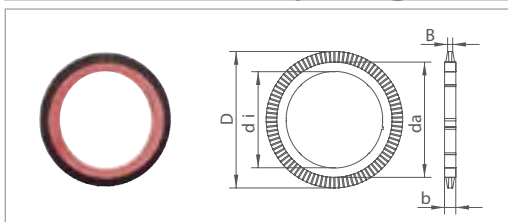

145	174.0	17.0		horsehair black	16.0	3	15	•		8511-0206-23
145	174.0	17.0		Chungking bristle black	16.0	3	14	•		8511-0206-33
145	174.0	17.0		PA 6.6 white 0.40 mm	16.0	3	15	•		8511-0206-43
145	174.0	17.0		Calcutta bristle grey	16.0	3	15	•		8511-0206-53
145	174.0	17.0		PA 6.6 white 0.70 mm	16.0	3	14	•		8511-0206-73
145	174.0	17.0		stainless steel wire 0.25 mm	16.0	3	14	•		8511-0206-83
145	174.0	17.0		horsehair black	16.0	3	10		•	8511-1206-23
145	174.0	17.0		Chungking bristle black	16.0	3	9		•	8511-1206-33
145	174.0	17.0		PA 6.6 white 0.40 mm	16.0	3	9		•	8511-1206-43
145	174.0	17.0		Calcutta bristle grey	16.0	3	8		•	8511-1206-53
145	174.0	17.0		PA 6.6 white 0.70 mm	16.0	3	10		•	8511-1206-73
145	174.0	17.0		goat hair white	16.0	3	11		•	8511-1206-93
145	174.0	17.0		PA 6.12 black 0.50 mm	16.0	3	8		•	8511-1206-X3

Overfeed and Postpinning Brush \emptyset 211 mm (D)



145	174.0	17.0		Calcutta bristle grey	18.5	3	16	•		8511-0211-53
-----	-------	------	--	-----------------------	------	---	----	---	--	--------------

ARTOS STENTERS

body dimensions				fill						Gutmann article-nr.
inner \varnothing (di/d2)	outer \varnothing (da)	width (b)	pitch circle \varnothing (TK)	fill material	trim	rows	operating width (B)	style		
mm	mm	mm	mm					straight	conv.	
										

Edge Cutting Brush \varnothing 60 mm (D)

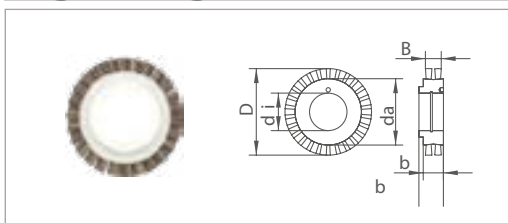

26	46.0	14 / 17		Chungking bristle black	7.0	2	10	•		8555-0060-12
----	------	---------	--	-------------------------	-----	---	----	---	--	---------------------

Pin Cleaning Brush

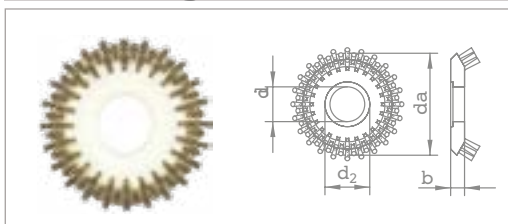

45/58	132.0	18.0		PA 6.6 white 0.40 mm	20.0	3				82-2322-4
45/58	132.0	18.0		stainless steel wire 0.25 mm	20.0	3				82-2322-8
45/58	132.0	18.0		crimped st. steel 0.30 mm	20.0	3				82-2322-9
45/58	132.0	18.0		crimped brass 0.30 mm	20.0	3				82-2322-10

Clip Cleaning Brush \varnothing 210/175 mm (D)

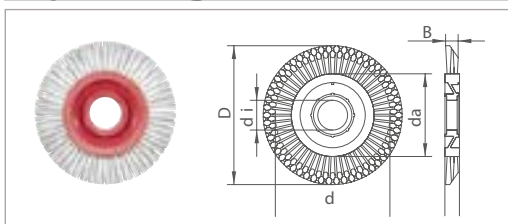

45	125.0	22.0		PA 6.6 white 0.70 mm	42.5	3	18			8541-4210-73
45	125.0	22.0		crimped st. steel 0.30 mm	42.5	3	20			8541-4210-83
45	125.0	22.0		crimped brass 0.30 mm	42.5	3	24			8541-4210-93

We offer the world's most extensive product portfolios of stenter brushes.
If, contrary to expectations, none of them fits your requirements,
please ask us to for an individual production of your stenter brush.